

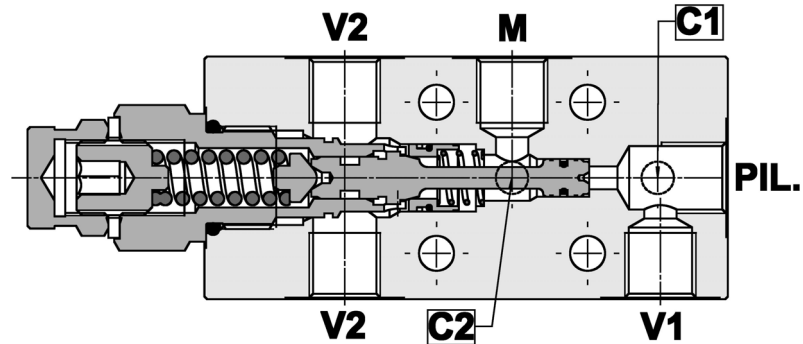

**Valvola overcenter singola, montaggio a flangia su C1/C2, attacco manometro
Single overcenter valve, gasket mounted on C1/C2, gauge port**

Rev.03-2010/08

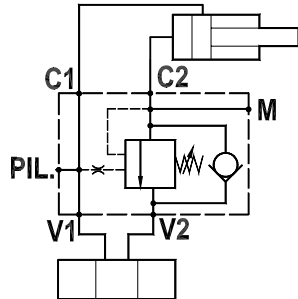

SPECIFICHE TECNICHE

Materiali: corpo in acciaio zincato. I componenti interni sono in acciaio trattato termicamente.

Portata max.: 35 l/min

Taratura max.: 350 bar

Rapporto di pilotaggio: 1 : 4 (a richiesta 1 : 8, 1 : 11)

Regolazione pressione: mediante vite

Campo di regolazione pressione: vedere pag.02

Peso: 1,000 Kg

TECHNICAL SPECIFICATIONS

Materials: body is in steel zinc plated. Internal parts are in hardened steel.

Rated flow: up to 35 l/min

Max. setting: 350 bar

Pilot ratio: 1 : 4 (1 : 8 and 1 : 11 on request)

Adjustment means: leakproof screw adjustment

Adjustable pressure range: see page 02

Weight: 1,000 Kg

DIAGRAMMA PERDITE DI CARICO - PRESSURE DROP CURVES

Viscosità olio 24 mm²/sec. (3,5 °E)
Temperatura 50 °C

Oil viscosity 24 mm²/sec. (3,5 °E)
Temperature 50 °C

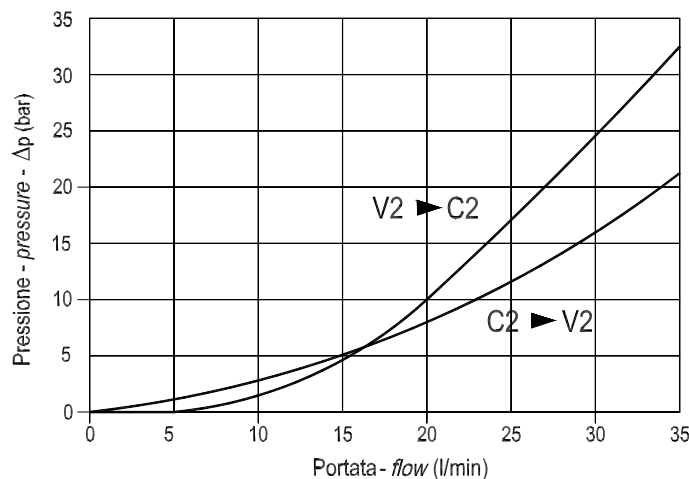

Valvola overcenter singola, montaggio a flangia su C1/C2, attacco manometro
Single overcenter valve, gasket mounted on C1/C2, gauge port

Rev.03-2010/08

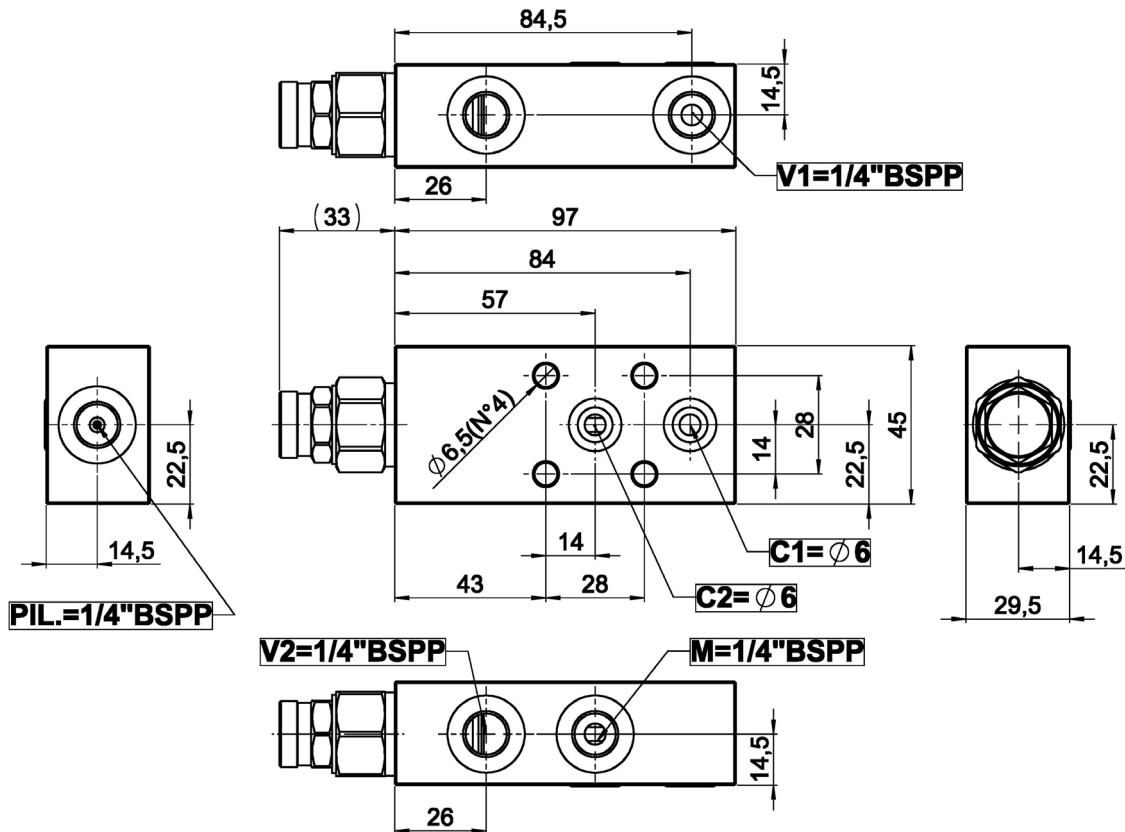

MOLLE - SPRINGS				*
Codice Code	Rapp. pil. Pilot ratio	Campo taratura min.-max. bar Adjustable pressure range bar	Increment. press. bar/giro vite Pressure increase bar/turn	Taratura standard bar Standard setting bar
20	1 : 4	60 - 250	65	170
	1 : 8	80 - 350	140	280
35	1 : 11	80 - 350	160	

ESEMPIO DI ORDINAZIONE - ORDERING CODE EXAMPLE

F P O 3 5 S 1 / 4 2 F P M 3 5 B

* "20" / "35":

Campi di taratura pressione - Adjustable pressure range

Rapporto di pilotaggio - Pilot ratio
 Omettere se std - Omit if std *

B = 1 : 8, C = 1 : 11